

链轮 SPROCKET
1" x 17.02mm

16B-1-2-3

链轮 SPROCKET 1" x 17.02mm

配对链条标准为DIN8187 ISO/R 606
For Chain Acc.to DIN8187 ISO/R 606

链轮 SPROCKET	mm
齿侧倒角半径 Tooth Radius r ₃	26.0
齿侧倒角宽 Radius Width C	2.5
齿宽 Tooth Width B ₁	16.2
齿宽 Tooth Width b ₁	15.8
齿宽 Tooth Width B ₂	47.7
齿宽 Tooth Width B ₃	79.6

链条 CHAIN	mm
节距 Pitch	25.4
内节内宽 Internal Width	17.02
滚子直径 Roller Diameter	15.88

*为焊接凸台 *Welding hub

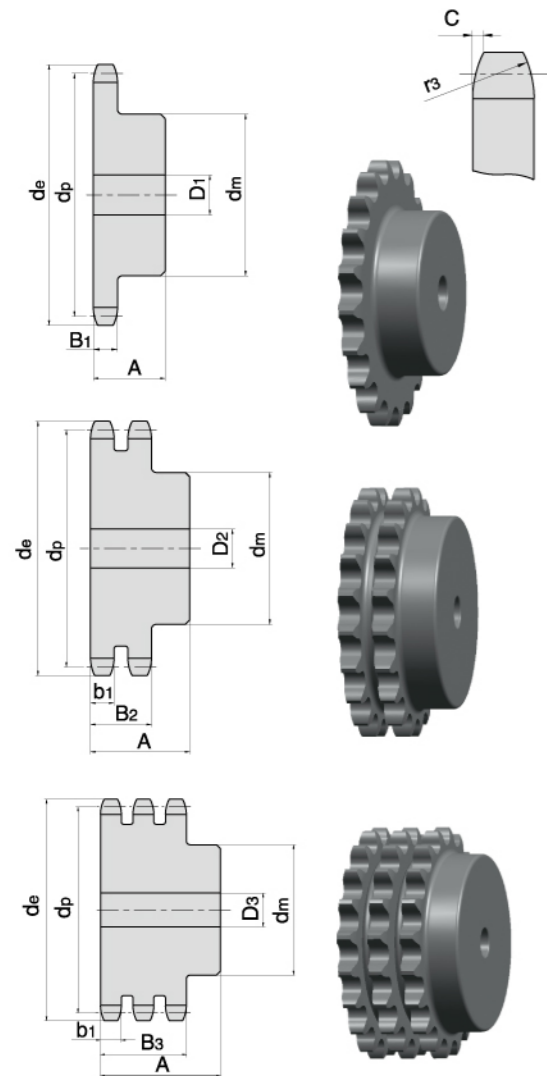

Z	de	dp	SIMPLEX			DUPLEX			TRIPLEX		
			dm	D1	A	dm	D2	A	dm	D3	A
8	77.0	66.37	42	16	35	42	16	65	42	20	95
9	85.0	74.27	50	16	35	50	16	65	50	20	95
10	93.0	82.19	55	16	35	56	16	65	56	20	95
11	101.5	90.14	61	16	40	64	20	70	64	25	100
12	109.0	98.14	69	16	40	72	20	70	72	25	100
13	117.0	106.12	78	16	40	80	20	70	80	25	100
14	125.0	114.15	84	16	40	88	20	70	88	25	100
15	133.0	122.17	92	16	40	96	20	70	96	25	100
16	141.0	130.20	100	20	45	104	20	70	104	25	100
17	149.0	138.22	100	20	45	112	20	70	112	25	100
18	157.0	146.28	100	20	45	120	20	70	120	25	100
19	165.2	154.33	100	20	45	128	20	70	128	25	100
20	173.2	162.38	100	20	45	130	20	70	130	25	100
21	181.2	170.43	110	20	50	130	25	70	*130	25	100
22	189.3	178.48	110	20	50	*130	25	70	*130	25	100
23	197.5	186.53	110	20	50	*130	25	70	*130	25	100
24	205.5	194.59	110	20	50	*130	25	70	*130	25	100
25	213.5	202.66	110	20	50	*130	25	70	*130	25	100
26	221.6	210.72	120	20	50	*130	25	70	*130	30	100
27	229.6	218.79	120	20	50	*130	25	70	*130	30	100
28	237.7	226.85	120	20	50	*130	25	70	*130	30	100
29	245.8	234.92	120	20	50	*130	25	70	*130	30	100
30	254.0	243.00	120	20	50	*130	25	70	*130	30	100
31	262.0	251.08	*120	25	50	*140	25	70	*140	30	100
32	270.0	259.13	*120	25	50	*140	25	70	*140	30	100
33	278.5	267.21	*120	25	50	*140	25	70	*140	30	100
34	287.0	275.28	*120	25	50	*140	25	70	*140	30	100
35	296.2	283.36	*120	25	50	*140	25	70	*140	30	100
36	304.6	291.44	*120	25	50	*140	25	70	*140	30	100
37	312.6	299.51	*120	25	50	*140	25	70	*140	30	100
38	320.7	307.59	*120	25	50	*140	25	70	*140	30	100
39	328.8	315.67	*120	25	50	*140	25	70	*140	30	100
40	336.9	323.75	*120	25	50	*140	25	70	*140	30	100
41	345.0	331.81	*125	25	68	*140	25	70	*160	30	100
42	353.0	339.89	*125	25	68	*140	25	70	*160	30	100
43	361.1	347.97	*125	25	68	*140	25	70	*160	30	100
44	369.1	356.05	*125	25	68	*140	25	70	*160	30	100
45	377.1	364.12	*125	25	68	*140	25	70	*160	30	100
46	385.2	372.20	*125	25	68	*140	25	70	*160	30	100
47	393.2	380.28	*125	25	68	*140	25	70	*160	30	100
48	401.3	388.36	*125	25	68	*140	25	70	*160	30	100
49	409.3	396.44	*125	25	68	*140	25	70	*160	30	100
50	417.4	404.52	*125	25	68	*140	25	70	*160	30	100
51	425.5	412.60	*125	25	68	*150	25	85	*180	30	110
52	433.6	420.68	*125	25	68	*150	25	85	*180	30	110
53	441.7	428.76	*125	25	68	*150	25	85	*180	30	110
54	448.3	436.84	*125	25	68	*150	25	85	*180	30	110
55	457.9	444.92	*125	25	68	*150	25	85	*180	30	110
56	466.0	453.01	*125	25	68	*150	25	85	*180	30	110
57	474.0	461.08	*125	25	68	*150	25	85	*180	30	110
58	482.1	469.16	*133	25	68	*150	25	85	*180	30	110
59	490.2	477.24	*133	25	68	*150	25	85	*180	30	110
60	498.3	485.23	*133	25	68	*150	25	85	*180	30	110
62	514.5	501.49	*133	25	68	*150	25	85	*180	30	110
64	530.7	517.65	*140	25	68	*160	25	90	*180	30	110
65	538.8	525.73	*140	25	68	*160	25	90	*180	30	110
66	546.8	533.80	*140	25	68	*160	25	90	*180	30	110
68	562.9	549.98	*140	25	68	*160	25	90	*180	30	110
70	579.2	566.15	*140	25	68	*160	25	90	*180	30	110
72	595.4	582.31	*140	25	68	*160	25	90	*180	30	110
75	619.7	606.56	*140	25	68	*160	25	90	*180	30	110
76	627.0	614.64	*140	25	68	*160	25	90	*180	30	110
78	643.3	630.81	*140	25	68	*160	25	90	*180	30	110
80	660.0	646.97	*140	25	68	*160	25	90	*180	30	110
85	699.9	687.39	*140	25	78	*160	25	90	*180	30	110
90	740.3	727.80	*140	25	78	*160	25	90	*180	30	110
95	781.1	768.22	*140	25	78	*160	25	90	*180	30	110
100	821.1	808.64	*140	25	78	*160	25	90	*180	30	110
110	902.0	889.48	*140	25	78	*160	25	90	*180	30	110
114	934.3	921.81	*140	25	78	*160	25	90	*180	30	110
120	982.8	970.32	*140	25	78	*160	25	90	*180	30	110
125	1023.3	1010.73	*140	25	78	*160	25	90	*180	30	110

链轮 PLATEWHEEL
1" x 17.02mm

16A-1-2-3

链轮 PLATEWHEEL 1" x 17.02mm

配对链条标准为DIN8187 ISO/R 606
For Chain Acc.to DIN8187 ISO/R 606

链轮 PLATEWHEEL	mm
齿侧倒角半径 Tooth Radius r ₃	26.0
齿侧倒角宽 Radius Width C	2.5
齿宽 Tooth Width B ₁	16.2
齿宽 Tooth Width b ₁	15.8
齿宽 Tooth Width B ₂	47.7
齿宽 Tooth Width B ₃	79.6

链条 CHAIN	mm
节距 Pitch	25.4
内节内宽 Internal Width	17.02
滚子直径 Roller Diameter	15.88

*为焊接凸台 *Welding hub

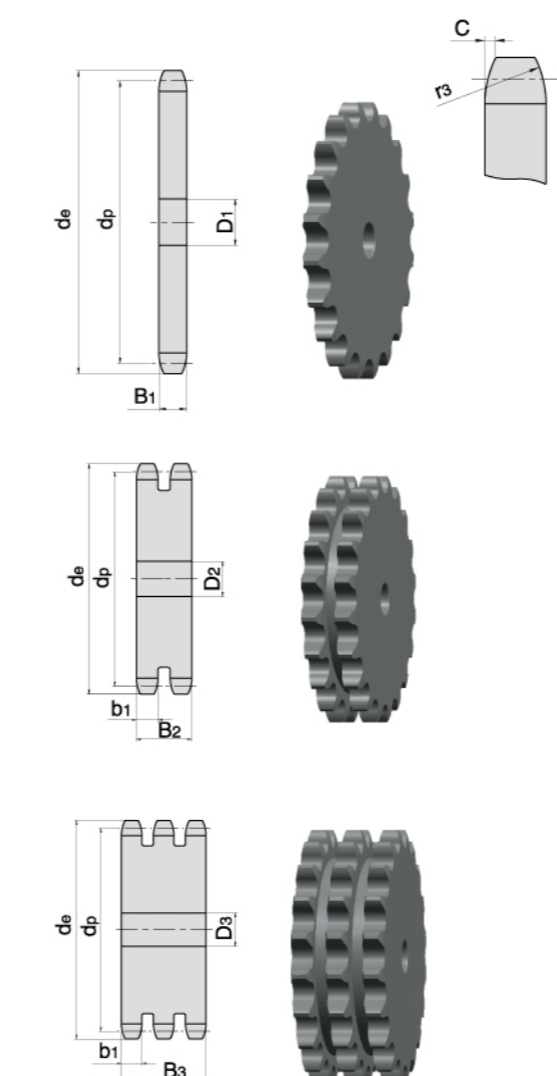

Z	de	dp	S	D	T
			D1	D2	D3
8	77.0	66.37	12	16	16
9	85.0	74.27	12	16	16
10	93.0	82.19	12	16	16
11	101.5	90.14	16	20	20
12	109.0	98.14	16	20	20
13	117.0	106.12	16	20	20
14	125.0	114.15	16	20	20
15	133.0	122.17	16	20	20
16	141.0	130.20	20	20	25
17	149.0	138.22	20	20	25
18	157.0	146.28	20	20	25
19	165.2	154.33	20	20	25
20	173.2	162.38	20	20	25
21	181.2	170.43	20	25	25
22	189.3	178.48	20	25	25
23	197.5	186.53	20	25	25
24	205.5	194.59	20	25	25
25	213.5	202.66	20	25	25
26	221.6	210.72	20	25	30
27	229.6	218.79	20	25	30
28	237.7	226.85	20	25	30
29	245.8	234.92	20	25	30
30	254.0	243.00	20	25	30
31	262.0	251.08	25	25	30
32	270.0	259.13	25	25	30
33	278.5	267.21	25	25	30
34	287.0	275.28	25	25	30
35	296.2	283.36	25	25	30
36	304.6	291.44	25	25	30
37	312.6	299.51	25	25	30
38	320.7	307.59	25	25	30
39	328.8	315.67	25	25	30
40	336.9	323.75	25	25	30
41	345.0	331.81	25	25	30
42	353.0	339.89	25	25	30
43	361.1	347.97	25	25	30
44	369.1	356.05	25	25	30
45	377.1	364.12	25	25	30
46	385.2	372.20	25	25	30
47	393.2	380.28	25	25	30
48	401.3	388.36	25	25	30
49	409.3	396.44	25	25	30
50	417.4	404.52	25	25	30
51	425.5	412.60	30	30	40
52	433.6	420.68	30	30	40
53	441.7	428.76	30	30	40
54	448.3	436.84	30	30	40
55	457.9	444.92	30	30	40
56	466.0	453.01	30	30	40
57	474.0	461.08	30	30	40
58	482.1	469.16	30	30	40
59	490.2	477.24	30	30	40
60	498.3	485.23	30	30	40
62	514.5	501.49	30	30	40
64	530.7	517.65	30	30	40
65	538.8	525.73	30	30	40
66	546.8	533.80	30	30	40
68	562.9	549.98	30	30	40
70	579.2	566.15	30	30	40
72	595				